

**ELECTRIC CHAIN HOIST**

**Operating  
manual**



## Safety First

Any hoisting equipment may have potential risks. Only those Authorized and Qualified Personnel who have shown that they have read and have understood this manual and that they are familiar with the proper operation and maintenance of the hoist should be permitted to inspect, maintain or operate the hoist. Otherwise it may result in serious injury, death, or property damage.



Important issues to remember during operation are provided at the hoist control stations, at various locations on the hoist and in the manuals by DANGER, WARNING, or CAUTION instructions or placards that alert personnel to potential hazards, proper operation, load limitations, and more.

**Hence, before operate the electrical chain hoist, please read through the manual and precautions.**



# Contents

Safety First	
1. Preface	01
2. Main specifications	02
2.1 Table of specifications	02
2.2 Machine degree and service life	03
2.3 Safety devices	05
2.4 Technical parameters of electric chain hoist	06
2.5 Electric Trolley	09
3. Safety rules	10
4. Installation	13
4.1 Identifying the parts	13
4.2 Voltage	13
4.3 Installation of electric chain hoist	14
4.4 Installation of electric trolley mounted electric chain hoist	17
5. Operation	20
6. Maintenance and Overhaul	21
6.1 Maintenance	21
6.2 Overhaul	22
7. Wiring diagram	27
8. Troubleshooting	29
9. Hoist operation and inspection	31

# 1

## Preface

The manual can assist you in properly installing, operating, and maintaining your electric chain hoist and ensure the hoist to operate safely and economically with the highest efficiency.

Before operating the hoist, please read through the manual to know about the correct procedure and operation means, as well as preventative maintenance to guarantee faithful and reliable service.

To ensure the needed replacement parts are sent in the shortest time, please provide us with the following data when contact us:

- (1) Type of the hoist you purchased
- (2) Product serial number of the hoist you purchased
- (3) Name of the part(s) needed (it is preferred to affix notes to the part(s))

We believe you will find the electric chain hoist can work for you satisfactorily for years. If you have any questions, please do not hesitate to contact us.

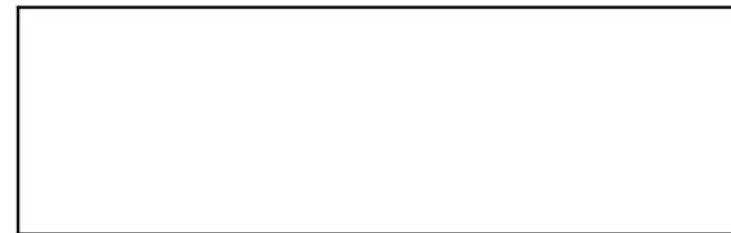

(Please note to ask your distributor to affix its seal.)

# 2

## Main specifications

### 2.1 Table of specifications

The specifications in the following table are applicable to all electrical chain hoists of Brand.

**Table 2.1 Specifications**

Item		Specification	
Range of Working Humidity(%)		85 or below85	
Range of Working Temperature(°C)		-20~+40	
Protection Class	Hoist	IP54	
	Push Button	IP65	
Power Supply		3 phase,200~440V,50/60Hz	
Noise Degree (dB)	Single Speed Hoist	80	
	Double Speed Hoist	81	
Chain Specifications	Limit Working Load	Nominal Diameter(mm)	Chain Internal Length(mm)
	0.25,0.5t	φ 6.3	19
	1t,2t,3t	φ 7.1	21
	1.5t,2t,3t	φ 10.0	30
	2.5t,3t,5t,7.5t	φ 11.2	34

Remarks:

- (1) If your working temperature and humidity are over the values of the table, please ask your Distributor for related data.
- (2) Original operation mode: The hoist is designed to vertically lift loads in normal atmosphere And working conditions.
- (3) The standard of noise degree is the value measured at one meter from the machine under Normal operation.

### 2.2 Machine degree and service life

The service and safety of the electric chain hoist can be guaranteed only under the condition that it is operated according to the followings:

- 1) The design of hoist conforms to 1Am of FEM (Table 2.21).
- 2) The description is detailed in table 2.2.
- 3) The average operation hours per day and total operation hours are calculated on the basis of load distribution.

**Table 2.2 Categories of machine degrees**

Load Type	Definition	Cubic meters Value Represented	Average Operation Hours Per Day(hours)						
			≤2	2-4	4-8	8-16	≤16	> 16	
1(light)	The mechanism and parts are frequently under light load, and there is no max load other than exceptional conditions.	$K \leq 0.50$	≤2	2-4	4-8	8-16	≤16	> 16	
2(middle)	The mechanism and parts are frequently under light load, but also under max load with low frequency.	$0.50 < K \leq 0.63$	≤1	1-2	2-4	4-8	8-16	≤16	
3(heavy)	The mechanism and parts are frequently under middle and heavy load.	$0.63 < K \leq 0.80$	≤0.5	0.5-1	1-2	2-4	4-8	8-16	
4(Super-heavy)	The mechanism and parts are frequently under max or nearly max Load.	$0.80 < K \leq 1.00$	≤0.25	0.25   0.5	0.5-1	1-2	2-4	4-8	
			1Bm	1Am	2m	3m	4m	5m	

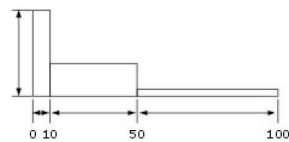

Operation time  
Load state 1

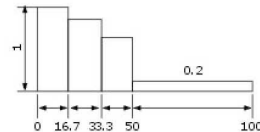

Operation time  
Load state 2

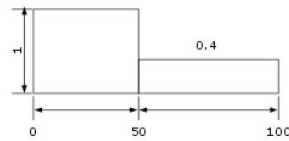

Operation time  
Load state 3

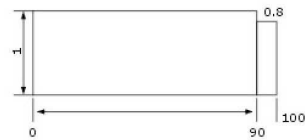

Operation time  
Load state 4

**Table 2.21 Standard of lifting motor**

Group		Intermittent Service			Continuous Operation
F.E.M	ISO	Cycles/h	Starts/h	(ED%)	Operation cycle/min
1 DM	M1	15	90	15	7.5
1 CM	M2	20	120	20	7.5
1 BM	M3	25	250	25	15
1 AM	M4	30	180	30	15
2 M	M5	40	240	40	30
3 M	M6	50	300	50	30
4 M	M7	60	360	60	60
5 M	M8	60	360	60	>60

## 2.3 Safety devices

### (1) Brake of the electric motor

The electromagnetic brake device is a unique design. It is characterized with the ability that the brake acts immediately the moment the power is cut off under full-load.

### (2) Hooks and hook safety latch

The hook is forged with tensile steel and heat treated to meet the demand on strength and hardness. The operation safety of the load hook is ensured by its 360° degree rotation.

### (3) Anti-phase protection device

It is special designed to control the circuit not to work and protect the electric motor from being burned in case of wiring error in the power supply.

### (4) Limit switch

The upper limit switch can automatically power off when the upper limit is reached, so as to ensure safety by preventing the chain from exceeding for safety.

### (5) Emergency stop switch(optional)

The button is used to stop the hoist in emergency. It is a red, mushroom shaped push button, located on the top of the push buttons. When the button is pushed, the power is cut off and the button is also locked automatically.

Turn it in clockwise to release the button and restart the hoist.

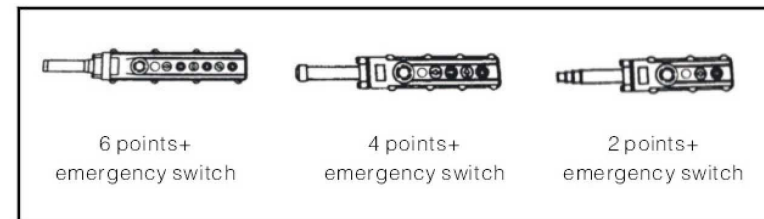

**ELECTRIC CHAIN HOIST**

**2.4 Technical parameters of electric chain hoist**

Capacity(ton)	0.25	0.5	1	1	1.5	2	2
Type	SGW-00301	SGW-00501	SGW-01002	SGW-01001	SGW-01501	SGW-02001	SGW-02002
Remove Litre of A1titude (m)	3/9						
Chain Diameter(mm)	6.3	6.3	6.3	7.1	10	10	7.1
Lifting Speed(m/min)	6.8	6.8	3.4	6.6	8.8	6.6	3.3
Motor Power(kW)	0.75	0.75	0.75	1.5	3.0	3.0	1.5
Power Supply(V)	200-440						
E.D.Rating(%)	40	40	40	40	40	40	40
Chain Fal I Number	1	1	2	1	1	1	2

Capacity(ton)	2.5	3	3	3	5	7.5
Type	SGW-02501	SGW-03003	SGW-03001	SGW-03002	SGW-05002	SGW-07503
Remove Litre of A1titude (m)	3/9					
Chain Diameter(mm)	11.2	7.1	11.2	10	11.2	11.2
Lifting Speed(m/min)	5.4	2.2	5.4	4.4	2.7	1.8
Motor Power(kW)	3.0	1.5	3.0	3.0	3.0	3.0
Power Supply(V)	200-440					
E.D.Rating(%)	40	40	40	40	40	40
Chain Fal I Number	1	3	1	2	2	3

**ELECTRIC CHAIN HOIST**

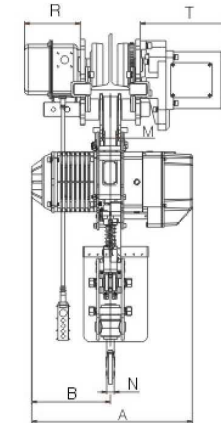
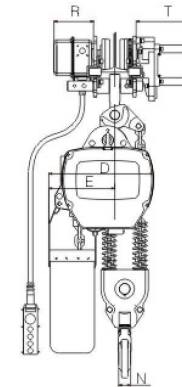
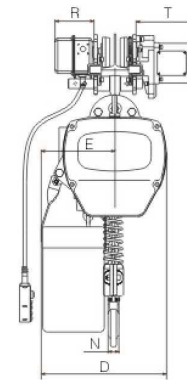
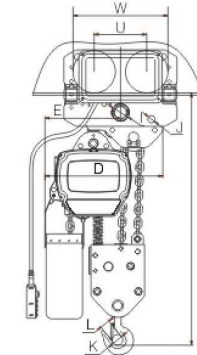
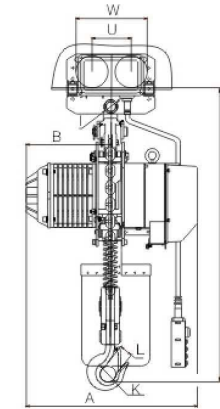
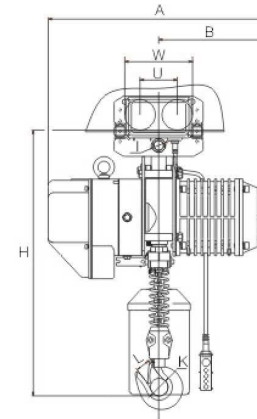

SGW-00301  
SGW-00501  
SGW-02001  
SGW-01001  
SGW-01501  
SGW-02501  
SGW-03001

SGW-01002  
SGW-02002  
SGW-03002  
SGW-05002

SGW-03003  
SGW-07503

**ELECTRIC CHAIN HOIST**

Type	Capacity (ton)	H	A	B	K	L	N
SGW-00301	0.25	630	460	230	φ 35	25	17
SGW-00501	0.5	630	460	230	φ 35	25	17
SGW-01002	1	695	460	230	φ 40	31	22
SGW-01001	1	650	520	260	φ 42	32	19
SGW-01501	1.5	770	615	295	φ 49	40	30
SGW-02001	2	770	615	295	φ 49	40	30
SGW-02002	2	815	520	260	φ 49	40	30
SGW-02501	2.5	830	615	295	φ 59	48	35
SGW-03003	3	940	520	260	φ 59	48	35
SGW-03001	3	830	615	295	φ 59	48	35
SGW-03002	3	930	615	295	φ 59	48	35
SGW-05002	5	1015	615	295	φ 60	48	43
SGW-07503	7.5	1200	615	295	φ 85	80	55

Type	I	J	W	U	R	T
SGW-00301	φ 35	28	206	115	142	231
SGW-00501	φ 35	28	206	115	142	231
SGW-01002	φ 40	31	206	115	142	231
SGW-01001	φ 42	32	206	115	142	231
SGW-01501	φ 49	40	237	138	142	231
SGW-02001	φ 49	40	237	138	142	231
SGW-02002	φ 49	40	237	138	142	231
SGW-02501	φ 59	40	265	157	142	231
SGW-03003	φ 59	48	265	157	142	231
SGW-03001	φ 59	48	265	157	142	231
SGW-03002	φ 59	48	265	157	142	231
SGW-05002	φ 59	48	296	178	142	231
SGW-07503	φ 60	31	296	178	142	231

**ELECTRIC CHAIN HOIST**

**2.5 Electric Trolley**

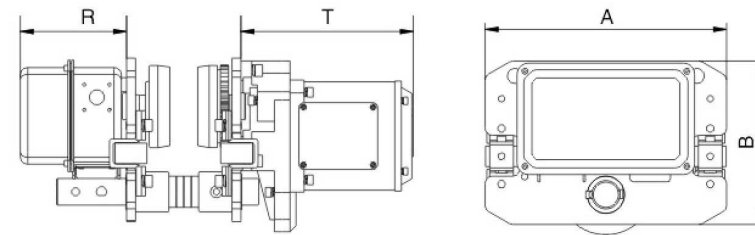

**Table 2.5 Specifications of Electric Trolley(mm)**

Type	Capacity (ton)	A	B	R	T	Speed (m/min) 50Hz	Motor (kW)	Least Radius of Gyration	Net Weight (kg)
STW-005	0.5	315	212	142	231	11/21	0.4	0.8	52-153
STW-01	1	315	212	142	231	11/21	0.4	0.8	52-153
STW-015	1.5	325	220	142	231	11/21	0.4	0.8	82-178
STW-02	2	325	220	142	231	11/21	0.4	0.8	82-178
STW-025	2.5	340	250	142	231	11/21	0.75	1.0	100-178
STW-03	3	340	250	142	231	11/21	0.75	1.0	100-178
STW-05	5	400	291	142	231	11/21	0.75	1.8	100-178
STW-075	7.5	400	291	142	231	11/21	0.75	2.0	100-178

## ELECTRIC CHAIN HOIST

# 3

## Safety rules

The hoist is not designed for hoisting, supporting or transporting persons. Any modification, including upgrade and changing hoisting speed, or any change of the hoist design must be authorized by the original manufacturer or qualified professional engineers.



**Danger**



**Danger**

It is forbidden to operate the hoist under the exposure of explosive gas.

- (1) Person who have related training and experience can operate the hoist
- (2) Before operating the hoist, please confirm the followings:
  - (a) the proper hoisting cable is used.
  - (b) the location of the cable should be indicated in the following diagram (Fig.3.1) and the safety latch must lock the hook properly.
  - (c) the load to be hoisted must be safe and firm.  
(it is recommended to use a proper hoisting basket or other devices)

## ELECTRIC CHAIN HOIST

- (3) The button must be operated stably and firmly.
- (4) Try best to avoid excessively inching operation.
- (5) Be sure that the motor has been completely stopped before operating in the reverse direction.
- (6) When finish operation, keep the control cable and the lower hook in the vertical and static state and never make it sway or slide.
- (7) When lifting, the weights must be kept balance. Never lift the weight which are not in balance.
- (8) Never use the hoist to drag load in the horizontal direction. ( Fig.3.2)
- (9) It is forbidden to lift the weights by using the chain to bind the weights. (Fig.3.3)

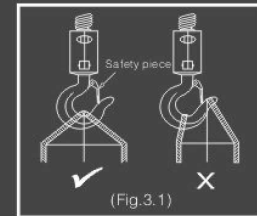

(Fig.3.1)

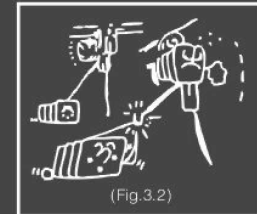

(Fig.3.2)

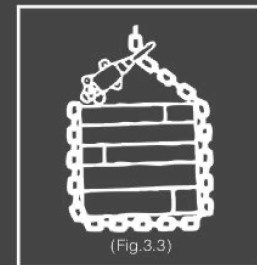

(Fig.3.3)



**Warning**

Never use the hoist chain as a welding electrode.





**Danger**

**Never stand under the load to hoist.**

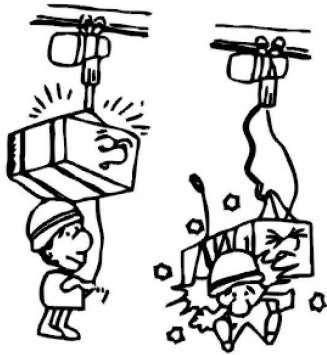

- (10) When in operation, the operator(s) must face and heed the load. Never turn back to overlook it.
- (11) It is risky to hoist anything over the rated value. Never try it.
- (12) Do not hoist anything when the chain is intertwined.
- (13) Inspect the chain regularly and ensure it is in good condition. If the chain is damaged, do not hoist anything.

# 4



## Installation

### 4.1 Identifying the parts

When unpacking, please check carefully to ensure the cable, gearbox, and motor shell are not damaged, and check whether the number of the following items is correct.

Every hoist should be equipped with the following standard accessories:

1	Chain container	one
2	Control cable	3 m
3	Push button	one

### 4.2 Voltage



**Caution**

If the difference between the voltage of the power supply and the standard voltage value is over  $\pm 10\%$ , within the abnormal voltage the operation may damage the motor, hence, before operation, please confirm the voltage value within the operation range.

### 4.3 Installation



## Warning

It is forbidden to link the power supply before the completion of installation.

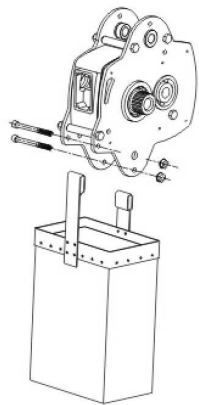

(Fig. 4.1)

4.3.1 Before installing the hoist, please confirm The whole hook assembly has been firmly Assembled to the hoist body(ensure the Chain connection pin is installed properly).

Remarks: If the hoist is equipped with electric trolley, the first step (to separate the upper hook from the hoist body) can be omitted, it is only required to install the hoist between two side plates of trolley and the upper hook.



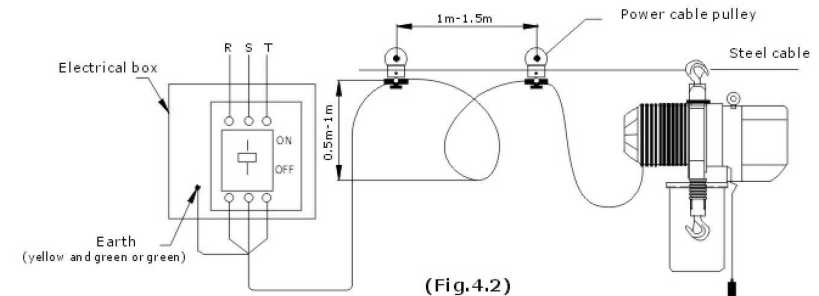

4.3.2 Assemble chain bag. (Fig.4.1)

4.3.3 Switch on the power supply and operate the push button, which must be performed by professional trained person. ( Fig.4.2)



(Fig.4.2)

#### 4.3.4 Operation test

- Press the  push button to lower the hoist directly until the limit spring Touches the limit switch, and the motor will stop automatically.
- Press the  button until the chain is totally in chain bag and the motor Stops.
- Test the function of the emergency stop switch(if the optional emergency Stop switch is purchased)Press button  or ,and press the emergency Stop switch at the same time to check whether the hook can stop immediately When the emergency switch is pressed, there will be no response when any other button is pressed. Finally, turn the emergency button in clockwise and it will bounce back to the original position. When it bounces back, the hoist can be operated again. If any of the above-mentioned tests is abnormal, it is required to check the distribution circuit and the automatic locking of the emergency switch.
- Check the direction of chain. All welding points should be of the same Direction (Fig.4.3).The operation can not be utterly proper unless the welding Points of chain are in the same line.



## Caution

If the chains rotate and are not in the same direction, it is forbidden to hang the load hook in the reverse direction to avoid risks. (Fig.4.4)

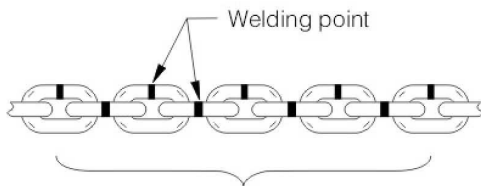

All welding points must be of the same direction

Fig.4.3

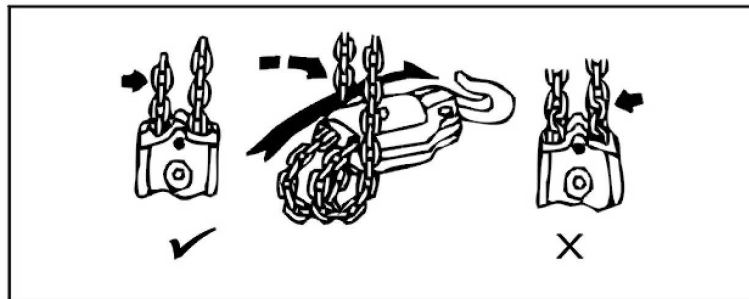

Fig.4.4

### (e) Chain lubrication

The degree of chain lubrication is an important factor for load Chain's life. They need a regular protect of machine oil or gear oil in order to prolong the chain's service life.

The process of lubrication:

1. Keep the chain without load vertically.
2. Erase dust and water stains on the chain.
3. Lubricate each link of chain connection and load pulley.

After the lubrication, lift the chain up and down without load in order to daub lubrication equably.(Fig 4.5)

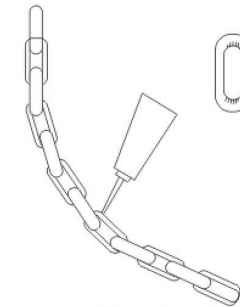

Fig.4.5

## 4.4 Installation of electric chain hoist with electric trolley (Fig.4.6)

### (a) Installation of trolley

- 1) Insert the suspension shaft into the side plate G, and fix them together with bolt and nut.
- 2) Input the suspension shaft with inner adjusting spacer inside, after putting the spacers, the total width should be about half of the width of traversing beam.
- 3) As the Fig. 4.6 shown, do installation step by step. Firstly, install suspender T into hoist body, and insert the shaft into suspender T.
- 4) Secondly, install the adjusting spacers on it. Put side plate S between trolley wheel and electric case. And fix with adjusting spacer.
- 5) The last step: using dowel pin and split pin to fix.

## ELECTRIC CHAIN HOIST

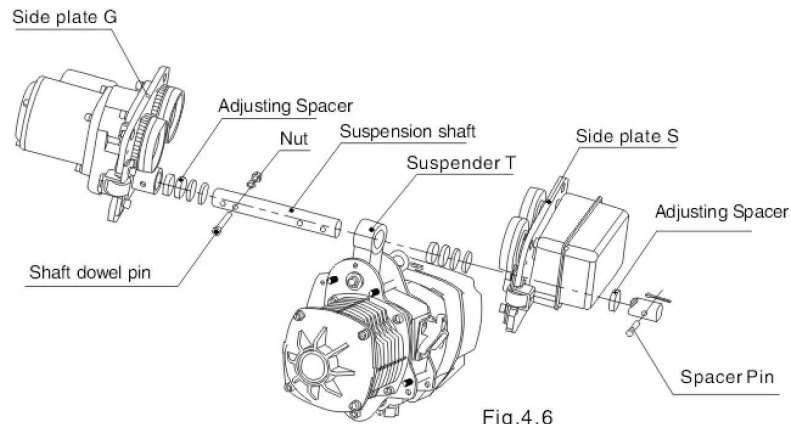

Fig.4.6

(b) Adjust trolley width (Fig. 4.7)

- (1) A refers to the measure value when two side plates stretch outwards totally.
- (2) B refers to the measure value when two side plates clamp inwards totally.
- (3) To adjust the number of thickness of inner spacers, makes B equal to the size when wheels on the two side plates close to beam.
- (4) To adjust the number and thickness of outer spacers, make  $A \leq B + 4\text{mm}$ .
- (5) The disassembling procedures refers to trolley installation, and fixed with dowel pin.

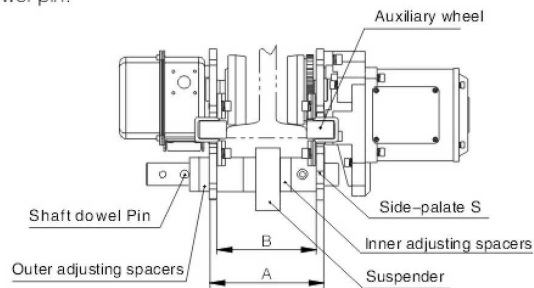

Fig.4.7

## ELECTRIC CHAIN HOIST



## Warning

It is forbidden to link the power supply before the completion of installation.

### Warning: please always fix with nuts.

- (c) Install the trolley on the traversing rail.
1. Under an exceptional circumstance, the most convenient installation way is to make the hoist trolley installed in the traversing rail from the end of the rail.
  2. If it is not available with the first way, please do installation as the followings:(See Fig.4.8)
    - 1) Remove the bolt from the suspension shaft hole A. Then insert it into the hole B. Fix it with split pin.
    - 2) Outward stretch side plate G and side plate S. Lift the trolley up to the traversing rail to keep both sides of wheel rail and traversing rail at the same level.
    - 3) Firstly support one side plate (G or S), then push the other side plate (S or G) with strength to prevent its shedding from rail. Keep the wheel rail and the traversing rail at the same level.
    - 4) Remove the bolt from the hole B, insert it to the hole A, and fix it with split pin.

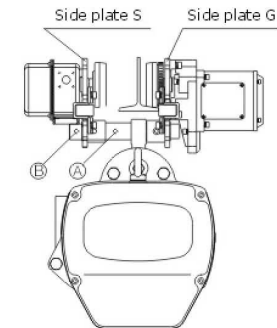

Fig 4.8

Trolley with the hoist mounted to traversing rail

# 5

## Operation

After the above-mentioned tests and operation testing, the hoist can be normally operated.

- (1) Before operation, the operator must have a clear and unobstructed view of the whole working area.
- (2) Before operation, the operator must check whether the whole working area is safe and free of risks.
- (3) When the trolley is operated, the operator must be careful to prevent from the situation that the reverse force caused by swing of the weights, maybe over the load of the trolley, while changing the trolley operation direction.
- (4) Do not operate a hoist with load chain that shows any sign of damage, Deformation, or excessive wear.
- (5) Never operate hoist without the protection of property functioning limit Switches



### Warning

Since the heavy load may result in unexpected risks, so all "safety rules", (refer to chapter 3) must be followed completely, and the operator must pay attention to and do perform the following when in operation

# 6

## Maintenance and overhaul



### Danger

Except monthly examination the performance of brake and limit switch, never have it maintained under loading condition.



### Danger

Before maintenance, be sure to lable the "danger"and" in overhaul" on the power supply and controller.

### 6.1 Maintenance

- (1) When the gear operates for more than 500 hours, the amount of lubrication oil should be checked, and after that, the lubrication oil should be checked every 3 months.  
Remarks: we recommend that the engine oil with the same grade of ISOVG46 should be used.
- (2) Check the dryness of the hoist parts frequently, and never abuse the hoist, otherwise its durability may be reduced.
- (3) If it is operated outdoors, please add a protection cover.

## 6.2 Overhaul

- (1) Daily inspection: before daily operation, please check the following items:
- (a) proper power supply.
  - (b) check the "up", "down" and "emergency stop switch" (if installed) without load.
  - (c) the motor works properly.
  - (d) there is no abnormal or excessive high noise.
  - (e) the hook latch of the load hook functions properly.
  - (f) the rotatable or movable parts and the limit switch as well as the brake function properly.
  - (g) the chain is lubricated well.

- (2) Monthly inspection



### Warning

In maintenance, please use the original parts recommended by the manufacturer.

- (a) Chain

Any distorted, extended, or worn chain can not lock well with chain wheel, resulting in breakdown or disengaging of the chain. To ensure the safe and proper operation, the inter-nodal distance (internal length and width) and external width of the chain must be checked monthly. If in the following situation, the chain must be replaced;

- (1) The internal length of the chain (p) is worn and extended to 5% above the values as listed in Table 6.1.
- (2) The wear and tear of the diameter of the chain link (d) is within the values as indicated in the following table (above 10% of the nominal diameter)

\*\*\*\*\* **When the wear and tear of the chain is high,** \*\*\*\*\*  
 \*\*\*\*\* **be sure to confirm the wear and tear of the chain wheel and guide rails** \*\*\*\*\*

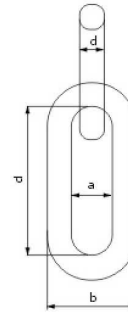

Fig.6.1

Diameter (mm) (d)	Capacity (ton)	Internal Length (mm) (p)	Internal Width (mm) (a)	External Width (mm) (b)
φ 6.3	0.25, 0.5	19	8	21
φ 7.1	1, 2, 3	21	8.9	23.7
φ 10.0	1.5, 2, 3	30	12.5	33
φ 11.2	2.5, 3, 5, 7.5	34	14	37

Table .6.1

- (b) Hook

Check for damage, cracks, nicks, gouges, deformation of the throat opening, wear on saddle or load bearing point, and twist. If it cracks or distorts over 5% of the size, it should be replaced. (please refer to the sizes in the following table).

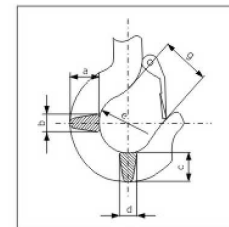

Fig.6.2

Capacity(ton)	a	b	c	d	e	g
0.25, 0.5	26	19	26	19	33	28
1	34	24	33	24	42	30
2	46	31	43	30	49	40
3	56	36	50	36	59	48
5	67	41	57	41	60	48
7.5	87	60	84	60	85	70

Table .6.2

## ELECTRIC CHAIN HOIST

### (c) Limit switch

Check whether the limit switch operates properly. And apply a thin layer of lubrication after it is cleaned to ensure the proper operation.



## Warning

It should be inspected by qualified electrician.

### (3) Annual overhaul



## Warning

The annual maintenance should be performed by original manufacturer or distributor.

## ELECTRIC CHAIN HOIST

- (a) The locking of gear should be checked to ensure there is no excessive wear or damage.
- (b) Replace the engine oil of the gearbox thoroughly.
- (c) After the above-mentioned checking and machine reassembling, to lift up and down with the weights several times before normal operation. If it is in good condition, then restart the operation.

### Specifications of chain bag

Serial Number of Chain Cases	Chain Specifications	Chain Length (m)	Size of Chain Bag (mm)	Material
8#	φ 6.3	<6	150 x 150 x 200L	canvas
8#	φ 7.1	<8.8	150 x 150 x 300L	canvas
12#	φ 10.0	8-16	210 x 210 x 450L	canvas
14#	φ 11.2	8-16	210 x 210 x 450L	canvas
Other	φ 6.3, φ 7.1 φ 10.0, φ 11.2	>20	/	Steel

### Chain gauge--to measure the wear and elongation

- (1) It is convenient to measure with the chain gauge provided by the manufacturer.
- (2) As shown in Fig.6.3 and Fig.6.4, measure the chain inter-nodal distance and diameter with the chain gauge.

## ELECTRIC CHAIN HOIST

- (3) Every link should be measured, and it must be replaced with a new one if any of the links is found to be abnormal.
- (4) The application of a worn, distorted, or extended chain may result in Breakdown of the chain.
- (5) Only authorized replacement load chain, with design specifications established by the hoist manufacturer, should be used when replacing load chain on the hoist. Load chain is specially designed for a particular hoist. Load chain from one manufacturer should not be used on a hoist manufactured by a different manufacturer.
- (6) Load chain should be replaced in accordance with the instructions outlined in the manual furnished by the manufacturer with the hoist. The original reeving arrangement of the hoist must be followed when replacing load chain.
- (7) The chain must be replaced in whole, no partial replacement is allowed.
- (8) When the chain is replaced for a second time, the transmission shaft, adjuster, and guide wheel should be replaced at the same time.

### Remarks:

- (1) The chain should be free of scored pockets, cracked or broken flanges, excessive pocket wear, or sharp edges from wear.
- (2) Load chain should be maintained in a lubricated condition.
- (3) After load chain has been replaced, rest and test limit switch before returning the hoist to regular service.

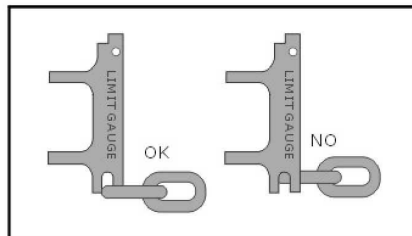

Fig .6. 4 Measure diameter

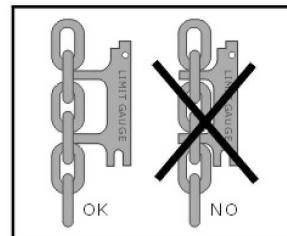

Fig .6.3 Measure inter nodal distance

## ELECTRIC CHAIN HOIST

# 7

## Wiring diagram

- (1) 2 Points button switch single speed wiring diagram 200–440V(24–48V);
- (2) 4 Points button switch single speed wiring diagram 200–440V(24–48V);

### 2Points Single Speed (Attached with Emergency stop)

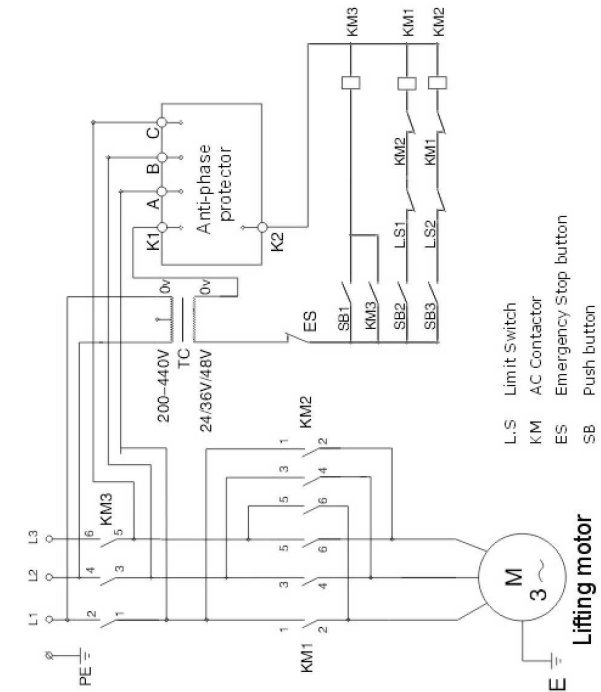



### 4Points Single Speed (Attached with Emergency stop)

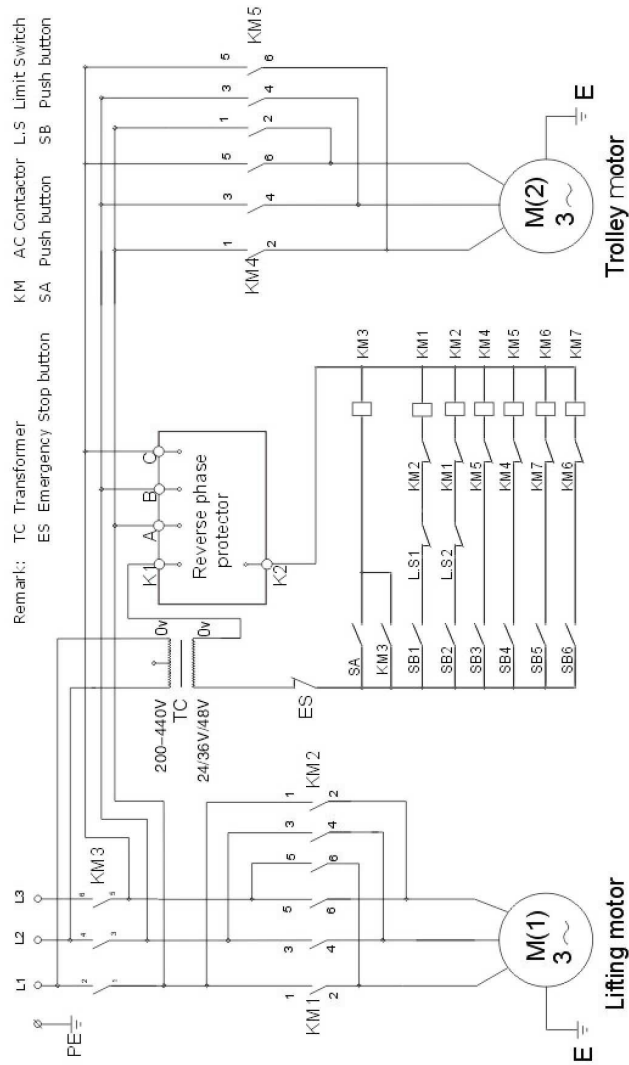

### ELECTRIC CHAIN HOIST

### ELECTRIC CHAIN HOIST

# 8

## Troubleshooting

If you experience trouble with the electric chain hoist, first check the following items. Should your electric chain hoist still not operate properly after you have made these checks, consult your dealer or local authorized service facility.

Conditions	Cause	Solution
The hoist can not be stopped	The coil of the contactor burns(it is in short circuit fault )	Replace the contactor
The brake slides	The motor brake wears	Replace the friction disc
The load chain/ chain wheel of the load hook makes abnormal noise	(1)The chain is not properly lubricated (2)The chain wheel is worn	(1)Lubrication (2)Replace the load chain and the chain wheel
Electric Leakage	(1)Imperfect earth (2)The dusts in air gather on electrical parts or the humidity is too high	(1)Provide perfect earth (2)Keep the electrical parts clean and make humidity low

**ELECTRIC CHAIN HOIST**

Conditions	Cause	Solution
Oil leakage	(1)The oil plug is not applied (2)The oil plug is loose (3)The oil plug gasket is not installed (4)The gasket is worn or deteriorated	(1) Install a proper plug (2) Tighten the plug (3) Install a proper plug gasket or replace with a new gasket
The hoist can not be operated	(1)The power phases are linked wrongly, which results in the start of the phase protection and makes it unable to operate (2)The power fuse is burned or the no-fuse switch is off (3)The fuse in the control circuit burns (4)The power cord or the wire of the control circuit breaks or is not linked properly (5)The voltage is too low (6)The motor makes a sound but does not rotate (7)The emergency switch is pressed (if installed) (8)The contactor is bad	(1) Exchange the power cords of the two phases. (2) Check whether the current is normal, replace a proper fuse or restart the non-fuse switch. (3) Check whether the current is normal, and replace a proper fuse. (4) Repair or replace the electricity wire that breaks or has bad contact. (5) Measure whether the voltage is over 10% lower than the standard voltage. (6) Check whether the motor phase is correct repair and make proper insulation. (7) Confirm the reason of pressing the emergency switch. (8) a. Operate the hoist manually, if it works properly, it means that the control coil or cable has bad contact—find out the location of bad contact and have it repaired. b. If the hoist can not be operated manually, it is necessary to check whether the main power supply is normal. If the main power supply is ok, it is caused by bad contact. If it is unable to output normally, the contactor should be replaced.

Contact your dealer or local authorized service facility if you are unable to solve the problem after corrective actions several times.

**ELECTRIC CHAIN HOIST**

# 9

## Hoist Operation and Inspection

As the manufacturer has no direct control over the hoist and its operation, conformance with good safety practice is the responsibility of the user and operating personnel.

**THE OPERATOR:**

**SHALL** Perform a daily inspection.  
 Visually inspect chain for nicks, gouges, and any types of deformation or damage, and check load chain for lubrication.  
 Visually inspect hook for nicks, gouges, deformation of the throat opening, wear on saddle or load bearing point, and twisting.  
 Visually inspect hook latched for proper operation or damage that does not allow proper operation.  
 Be familiar with all operating controls of the hoist.  
 Only attach loads to the hoist load hook that do not exceed the rated load capacity.  
 Verify that load will be properly balanced when lifted.  
 Verify that when the load is lifted, it will clear all material, machinery, or other obstructions in the area.  
 Avoid unnecessary inching and quick reversals of direction.

**SHALL NOT** Operate hoist if it is tagged with an out-of-order sign.  
 Operate hoist when the hoist is restricted from forming a straight line from top hook to load hook in the direction of loading.  
 Use the hoist load chain as a sling to wrap around the load.  
 Use the hoist to lift, support, or transport people.  
 Attempt to lengthen the load chain or repair damaged load chain.  
 Operate a hoist on which the safety placards or decals are missing or illegible.  
 Adjust or repair the hoist unless qualified to perform such adjustment or repairs.  
 Lift the load with two or more hoists at the same time, its dangerous.  
 For extreme conditions, it should lift carefully within the range of the sufficient load capacity.  
 Permit to modify the hoist. If necessary call for the manufacturer.